

The BARBER ROAD RAKE Model 200T

H. Barber & Sons, Inc. has developed the ROAD RAKE, the safest, fastest and most efficient means of removing debris from roadways. Retreads, mufflers and other debris can be removed from the road surface without the operator leaving the safety of the vehicle.

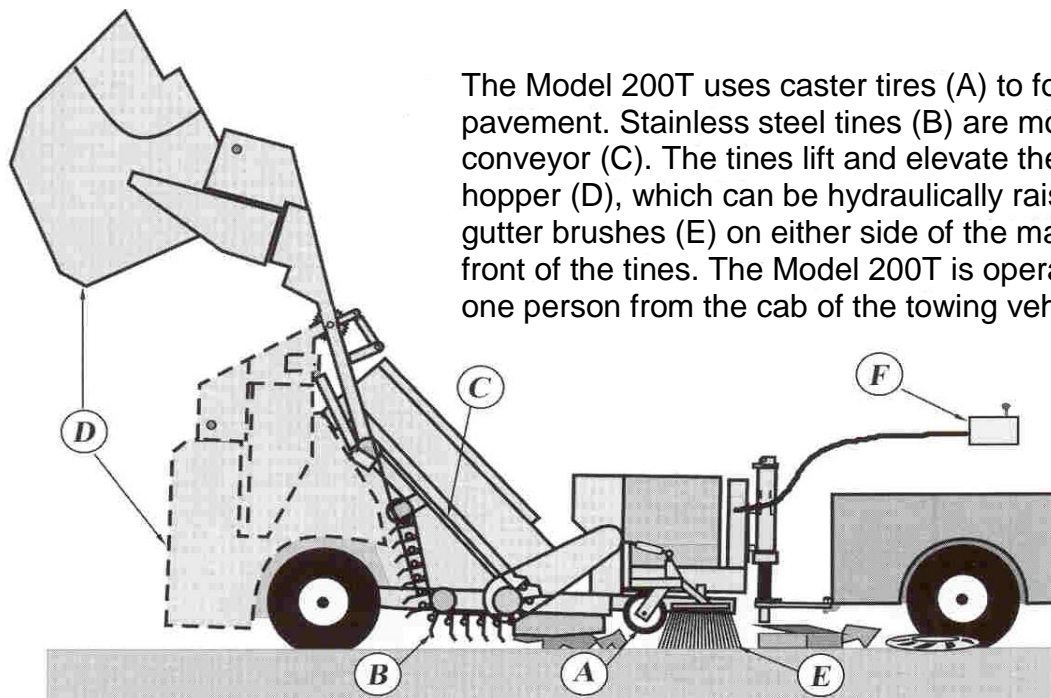

The Model 200T uses caster tires (A) to follow the contour of the pavement. Stainless steel tines (B) are mounted on a bar flight conveyor (C). The tines lift and elevate the unwanted debris to the hopper (D), which can be hydraulically raised and dumped. Two gutter brushes (E) on either side of the machine pull material in front of the tines. The Model 200T is operated electronically (F) by one person from the cab of the towing vehicle.

Specifications

HEIGHT..... 8'5" 2,6 m
 WIDTH.....8'4" 2,5 m
 LENGTH.....15'8" 4,8 m
 WEIGHT.....6000lbs. 2722 kg
 TIRES.....235/85R/16
 CLEANING WIDTH Min.....9'10" 3,0 m
 CLEANING WIDTH Max.....11'5" 3,5 m

CLEARANCE HEIGHT.....9'4" 2,8 m
 DUMP HEIGHT.....8'7" 2,6 m
 CLEANING SPEED.....1-18mph 1-29 km/hr
 HIGHWAY SPEED.....55mph 85 km/hr
 HOPPER CAPACITY.....4 cu yds. 3,05 m³
 TONGUE WEIGHT.....1900lbs. 862 kg

Operating Features

DEBRIS REMOVED Retreads, mufflers, hubcaps, cardboard, wood, paper, cans & litter.
DRIVE TRAIN The tow vehicle of the unit provides hydraulic power to the conveyor belt, gutter brushes, hitch and lift mechanisms of the 200T. An electrical control box activates all functions.
TOWING VEHICLE We recommend a one-ton pickup or larger truck, with pintle hitch. The Model 200T may be towed by a tractor or truck.
APPLICATIONS The ROAD RAKE removes debris from roadways, parks, parking lots, open fields, stadiums and along curbs & barricades.
WARRANTY H. Barber & Sons, Inc. warrants the Model 200T to be free from defects in parts and workmanship for 500 hours or one year, whichever occurs first.

BARBER

**The
ONLY Way
to Clear
Roadway
Debris!**



ROAD RAKE